

Southern Cross

TX-250 / 350 / 550

TRAVELLING IRRIGATORS

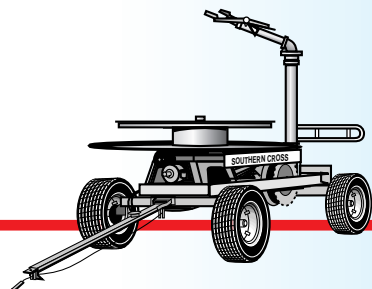

Southern Cross

TX-250 / 350 / 550

TRAVELLING IRRIGATORS

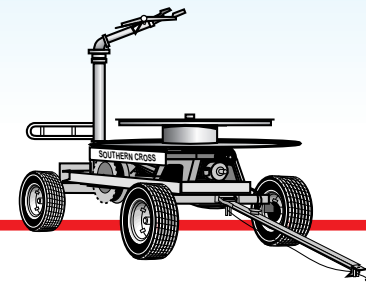

RUGGED, POWERFUL IRRIGATION

RUGGED, POWERFUL IRRIGATION

Overall dimensions and specifications TX-250/350 ...

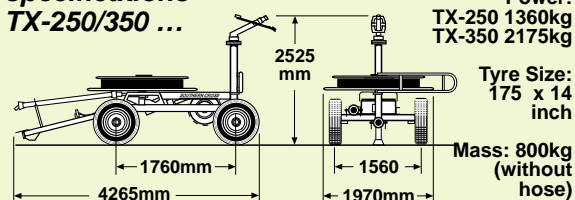

Rated Pulling Power:
TX-250 1360kg
TX-350 2175kg

Tyre Size:
175 x 14 inch

Mass: 800kg (without hose)

Overall dimensions and specifications TX-550...

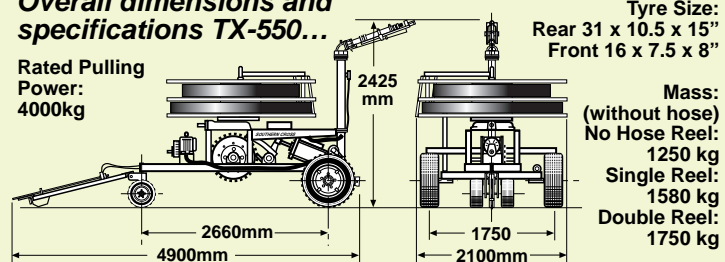

Rated Pulling Power: 4000kg

Tyre Size:
Rear 31 x 10.5 x 15"
Front 16 x 7.5 x 8"

Mass:
(without hose)
No Hose Reel: 1250 kg
Single Reel: 1580 kg
Double Reel: 1750 kg

TX-550 Irrigator Models.....

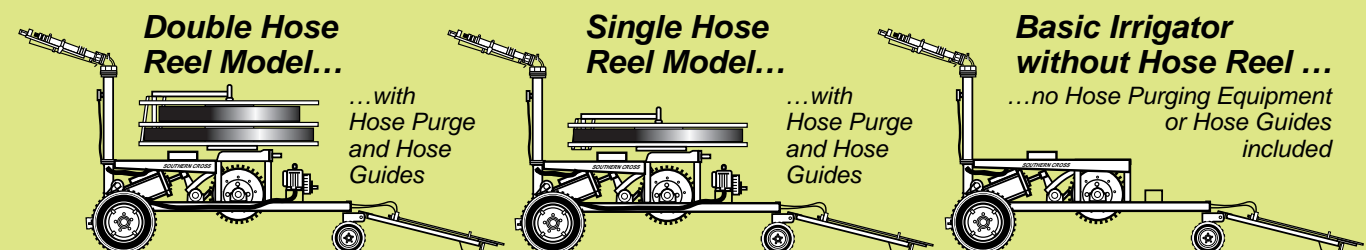

As Tyco policy is one of constant improvement, we reserve the right to make specification changes without notice and without incurring liability.

Distributed by... Ellis Tanks
5 Lucinda Street
Toowoomba Q 4350

P: 07 46 357 507
F: 07 46 357 507
M: 0427 716 087

Email: glenn@ellistanks.com.au
Web: www.ellistanks.com.au

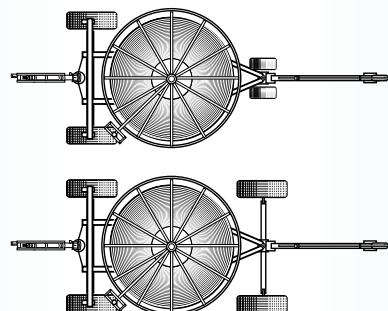

TX-550 OPTIONAL STEERING AND UNDERCARRIAGE

Standard tricycle undercarriage gives centre point steering for highly accurate tracking.

Beam steering and wide track front axle available as option for special crop requirements.

A division of **tyco** Flow Control Pacific Pty Ltd A.B.N. 83 000 922 690

Applications

- **AGRICULTURE** —
Small Crops, Broadacre, Turf Farms, Nurseries.
- **TURF WATERING** —
Playing Fields, Parks and Gardens, Lawn Cemeteries, Golf Courses, Race Courses.
- **DUST CONTROL** —
Mining, Construction Sites.

Features

- **Self-Propelled**
- **Auto Stop**
- **Heavy Duty Design**
- **P.T.O. Hose Reel**
- **Adjustable Speed**
- **Power to Handle all Conditions**
- **Positive Drive via Winch Cable & Anchor**
- **Hot Dip Galvanised**
- **Piston Type Water Motor**
- **Self-cleaning In-line Filter for Water Motor**





TX-250 / 350 / 550 TRAVELLING IRRIGATORS

MODEL

SPECIFICATIONS

TX-250



IRRIGATOR MODEL: TX-250.
SPRINKLER: Nelson SR100 or SR150 with ring nozzle set.
HOSE: 100, 150 or 200 metres X 2.5 inch or...
 100, 150 or 200 metres X 3 inch.
FLOW RATE: 5 to 17 litres per second.
OPERATING PRESSURE RANGE: 400 to 550 kPa.
TRAVEL DISTANCE PER RUN: 200, 300 or 400 metres.
WETTED WIDTH: 72 to 116 metres.
DRIVING MECHANISM: Powerful piston type water motor with lever action drive to large diameter cable winch.
RATED PULLING POWER: 1360 kg.
CONSTRUCTION: Heavy duty welded steel chassis all hot dip galvanised.
OPTIONAL EXTRAS: Rear wheel brakes, horizontal hose guide roller, hose purging compressor (std. on TX-250F), high flotation tyres (10.5 inch wide x 15 inch rims).

TX-350



IRRIGATOR MODEL: TX-350.
HOSE: 200 metres X 3 inch or...
 150 or 200 metres X 3.5 inch or...
 150 metres X 4 inch
SPRINKLER: Nelson SR150 with ring nozzle set.
FLOW RATE: 7 to 28 litres per second.
OPERATING PRESSURE RANGE: 400 to 550 kPa.
TRAVEL DISTANCE PER RUN: 300 or 400 metres.
WETTED WIDTH: 79 to 120 metres.
HOSE PURGING COMPRESSOR: Fitted as standard.
DRIVING MECHANISM: Powerful piston type water motor with lever action drive to large diameter cable winch.
RATED PULLING POWER: 2175 kg
HOSE REEL: P.T.O. driven with hose guide.
CONSTRUCTION: Heavy duty welded steel chassis all hot dip galvanised.
OPTIONAL EXTRAS: Rear wheel brakes, horizontal hose guide roller, high flotation tyres (10.5 inch wide x 15 inch rims).

TX-550



IRRIGATOR MODEL: TX-550.
HOSE: 200 metres X 3.5, 4 or 4.5 inch or...
 300 metres X 4 or 4.5 inch
SPRINKLER: Nelson SR200 with ring nozzle set.
FLOW RATE: 15.6 to 43 litres per second.
OPERATING PRESSURE RANGE: 400 to 550 kPa.
TRAVEL DISTANCE PER RUN: 400 or 600 metres.
WETTED WIDTH: 104 to 143 metres.
HOSE PURGING COMPRESSOR: Fitted as standard.
BRAKES: Fitted with adjustable rear wheel brakes.
DRIVING MECHANISM: Powerful piston type water motor with lever action drive to large diameter cable winch.
RATED PULLING POWER: 4000 kg
HOSE REEL: P.T.O. driven single or double reel with hose guide.
CONSTRUCTION: Heavy duty welded steel chassis all hot dip galvanised.
OPTIONAL EXTRAS: Horizontal hose guide roller, sprinkler standpipe extension, wide track front axle.

TX-250 / 350 / 550 TRAVELLING IRRIGATORS

PERFORMANCE DATA

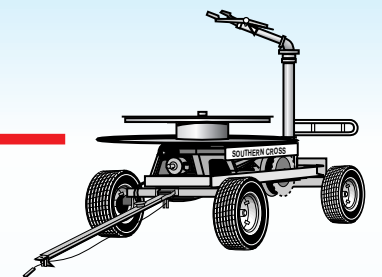

Nozzle Diam. mm	Sprinkler Pressure kPa	Flow Rate l/sec	Friction Loss in Hose kPa	Sprinkler Wetted Width m	Lane Spacing m	Area Irrig. Per run ha	Average Application Rate mm/hr	Depth of Water Applied mm				
								4hr Run	7hr Run	11hr Run	23hr Run	47hr Run
TX-250A 200m Spray Run (100m x 2.5 inch Hose) Nelson SR100 Big Gun Sprinkler with Ring Nozzle Set												
18	413	5.1	40	72	50	1.01	5.2	8	13	20	43	86
23.6	550	12.0	207	93	65	1.30	7.2	13	23	36	76	155
TX-250B 300m Spray Run (150m x 2.5 inch Hose) Nelson SR100 Big Gun Sprinkler with Ring Nozzle Set												
18	413	5.1	60	72	50	1.50	5.2	5	8	13	28	58
22.7	550	10.3	227	91	64	1.94	6.5	8	13	20	43	89
TX-250C 400m Spray Run (200m x 2.5 inch Hose) Nelson SR100 Big Gun Sprinkler with Ring Nozzle Set												
18	413	5.1	80	72	50	2.02	5.2	-	8	10	20	43
21.8	550	9.2	243	87	61	2.43	6.4	-	10	15	30	64
TX-250D 200m Spray Run (100m x 3 inch Hose) Nelson SR150 Big Gun Sprinkler with Ring Nozzle Set												
21.8	413	6.9	17	79	55	1.13	5.8	10	15	25	51	107
34	550	24.0	225	116	81	1.62	9.4	20	38	58	122	249
TX-250E 300m Spray Run (150m x 3 inch Hose) Nelson SR150 Big Gun Sprinkler with Ring Nozzle Set												
21.8	413	6.9	226	79	55	1.66	5.8	5	10	15	36	71
32	550	19.9	239	110	77	2.31	8.7	13	23	33	71	145
TX-250F 400m Spray Run (200m x 3 inch Hose) Nelson SR150 Big Gun Sprinkler with Ring Nozzle Set												
21.8	413	6.9	34	79	55	2.23	5.8	-	8	13	25	53
30	550	16.4	222	104	73	2.91	8.0	-	15	23	46	97
TX-350A 400m Spray Run (200m x 3 inch Hose) Nelson SR150 Big Gun Sprinkler with Ring Nozzle Set												
21.8	413	6.9	34	79	55	2.23	5.8	-	8	13	25	53
30	550	16.4	222	104	73	2.91	8.0	-	15	23	46	97
TX-350B 300m Spray Run (150m x 3.5 inch Hose) Nelson SR150 Big Gun Sprinkler with Ring Nozzle Set												
21.8	413	6.9	12	79	55	1.66	5.8	-	10	15	36	71
35.8	550	28.1	231	120	84	2.55	10.2	-	28	43	91	188
TX-350C 400m Spray Run (200m x 3.5 inch Hose) Nelson SR150 Big Gun Sprinkler with Ring Nozzle Set												
21.8	413	6.9	17	79	55	2.23	5.8	-	8	13	25	53
35.8	550	28.1	274	120	84	3.40	10.2	-	20	33	69	140
TX-350D 300m Spray Run (150m x 4 inch Hose) Nelson SR150 Big Gun Sprinkler with Ring Nozzle Set												
21.8	413	6.9	5	79	55	1.66	5.8	-	10	15	36	71
35.8	550	28.1	122	120	84	2.55	10.2	-	28	43	91	188
TX-550B 400m Spray Run (200m x 3.5 inch Hose) Nelson SR200 Big Gun Sprinkler with Ring Nozzle Set												
32.8	413	15.6	132	104	73	2.91	7.7	-	13	20	46	91
37.1	550	24.0	266	122	85	3.44	8.5	-	18	28	58	119
TX-550C 400m Spray Run (200m x 4 inch Hose) Nelson SR200 Big Gun Sprinkler with Ring Nozzle Set												
32.8	413	15.6	63	104	73	2.91	7.7	-	13	20	46	91
42.2	550	32.5	225	134	94	3.77	9.5	-	23	33	71	145
TX-550A 600m Spray Run (300m x 4 inch Hose) Nelson SR200 Big Gun Sprinkler with Ring Nozzle Set												
32.8	413	15.6	88	104	73	4.37	7.7	-	10	15	30	61
39.6	550	28.1	258	128	90	5.43	9.0	-	13	20	43	89
TX-550E 400m Spray Run (200m x 4.5 inch Hose) Nelson SR200 Big Gun Sprinkler with Ring Nozzle Set												
32.8	413	15.6	48	104	73	2.91	7.7	-	13	20	46	91
46.5	550	42.7	212	143	100	4.05	10.9	-	28	43	89	180
TX-550D 600m Spray Run (300m x 4.5 inch Hose) Nelson SR200 Big Gun Sprinkler with Ring Nozzle Set												
32.8	413	15.6	48	104	73	4.37	7.7	-	10	15	30	61
44.2	550	37.3	245	139	97	5.87	10.2	-	15	25	53	107